

CHARACTERISTICS

- SINGLE-ACTING PNEUMATIC PUMP;
- PUMP: 2 cm³ / CYCLE;
- RATIO: 50:1;
- 2KG GREASE RESERVOIR WITH SPRING LOADED FOLLOWER PLATE;
- MINIMUM LEVEL SENSOR AS STANDARD;
- AIR PRESSURE: FROM 3 TO 6 BAR (44-88 PSI);
- PUMP GREASE UP TO NLGI 2.

A SIMPLE YET VERSATILE PNEUMATIC PUMP

IDEAL FOR USE IN SMALL AND MEDIUM SINGLE LINE PROGRESSIVE DIVIDER SYSTEMS

LOCOPUMP S3 is an ideal single acting pneumatic pump generally used in single line progressive divider lubrication systems such as nP- nPr, SMX, SMO, SMP or SMPM.

LOCOPUMP S3 is available with 0.5 and 2 kg reservoir with spring loaded follower plate, which means it can easily handle NLGI grade 2 grease.

The transparent reservoir allows the user to clearly see the quantity of grease remaining and a low level grease switch is present to provide remote alarm signals to the machine it is mounted on. Additionally, the reservoir lid can be installed with a High level or a Dropsa continual level sensing device.

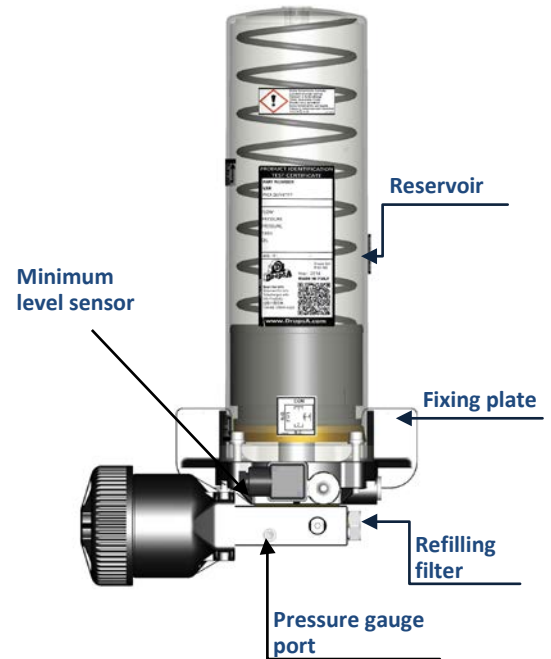

High Reliability is guaranteed by the use of hardened steel in the construction in all the pumping element components and the pump piston is manufactured in ground hardened steel.

The front Fill port is also equipped with a filling filter to ensure that only clean lubricant enters the reservoir.

The pump provides a simple but very cost effective solution for use on many small to mid range grease lubrication systems and is ideal to be used on machines where compressed air is available.

TECHNICAL INFORMATION

TECHNICAL CHARACTERISTICS	
Air pressure	44 ÷ 88 psi (3 ÷ 6 bar)
Compressed air inlet	G 1/8 UNI - ISO 228/1 with cone seating for 6mm tube
Reservoir refilling	Grease nipple with check valve type UNI 7663 – "A" – 1/8" NPT
Lubricant outlet	G ¼ UNI – ISO 228/1
Reservoir return	G ¼ UNI – ISO 228/1
Fixed delivery	2 cm ³ /stroke
Adjustment delivery (kit 3133390)	0.5 ÷ 2 cm ³ /stroke
Lubricants	Grease max NLGI 2
Piston total stroke	36.5 mm
Operating temperature	41 ÷ 122 °F (+5 ÷ +50°C)

APPLICATIONS

- LUBRICATION IN VEHICLES AND MOBILE PLANTS
- MACHINE TOOLS: AS MACHINES FOR WORKING SHEET METAL OR WOOD
- BENDING MACHINES
- INJECTION PRESSES FOR PLASTICS

DIMENSIONS (NOT TO SCALE)

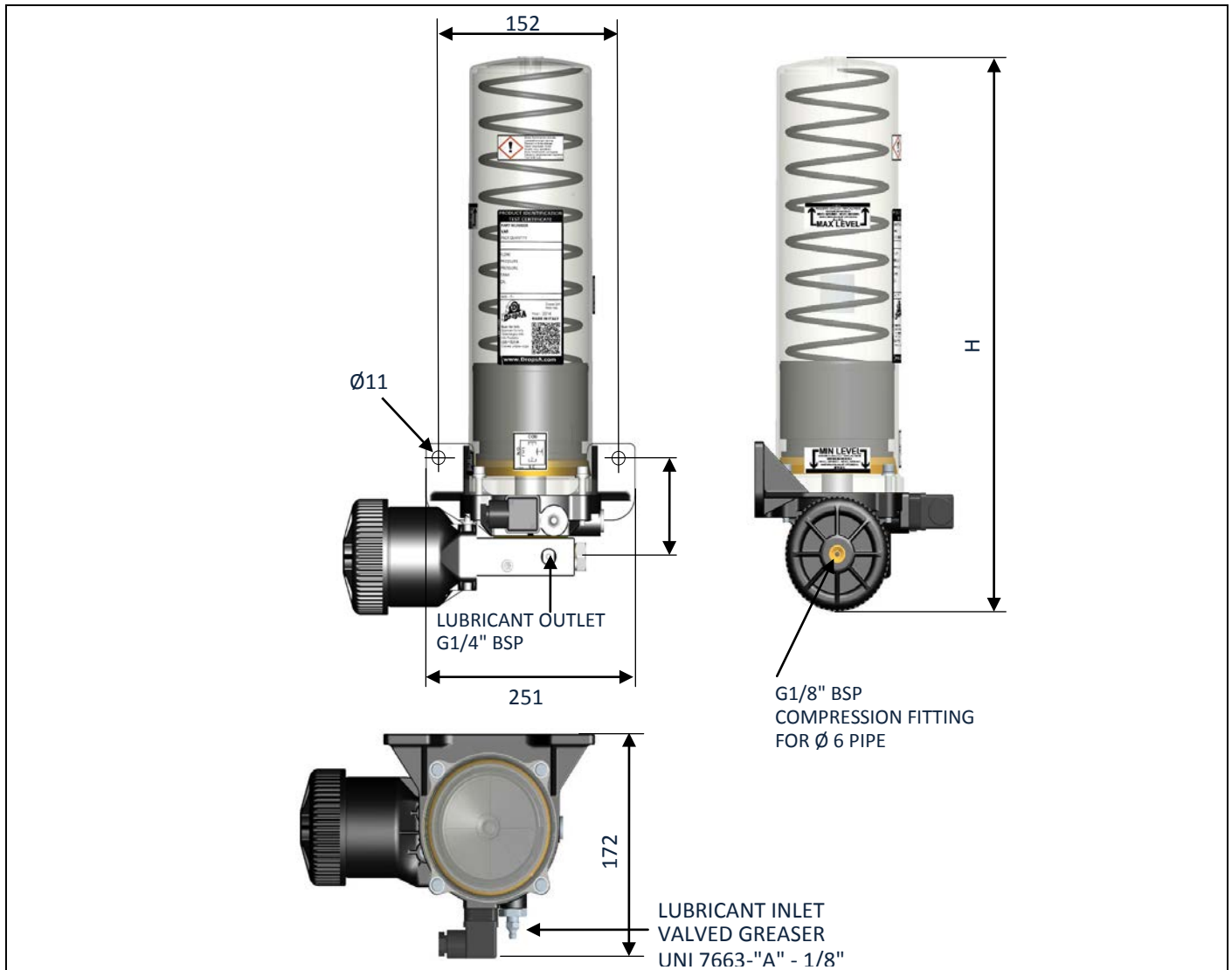

ORDERING INFORMATION

DESCRIPTION	RESERVOIR	P. No	Q.ty
LOCOPUMP S3 R=50:1	4.4 lb (2 Kg)	3413050	<input type="radio"/> _____
LOCOPUMP S3 R=50:1	1.1 lb (0.5 Kg)	3413060	<input type="radio"/> _____
Preloaded LOCOPUMP S3 R=50:1	4.4 lb (2 Kg)	3413050C	<input type="radio"/> _____

SPARE PARTS

DESCRIPTION	P. No	Q.ty
Serbatoio 2 Kg (4,4 lb)	3044522	<input type="radio"/> _____
Serbatoio 0.5 Kg (1,1 lb)	3044525	<input type="radio"/> _____
Squadra di sostegno	3045202	<input type="radio"/> _____
Corpo pompa	3413502	<input type="radio"/> _____
Sensore di minimo livello	1655183	<input type="radio"/> _____
Filtro di caricamento	712100	<input type="radio"/> _____
Replacement gaskets Kit	3133936	<input type="radio"/> _____
Pump delivery adjustment kit	3133390	<input type="radio"/> _____

Distributor Info: