

DL-32 Injector

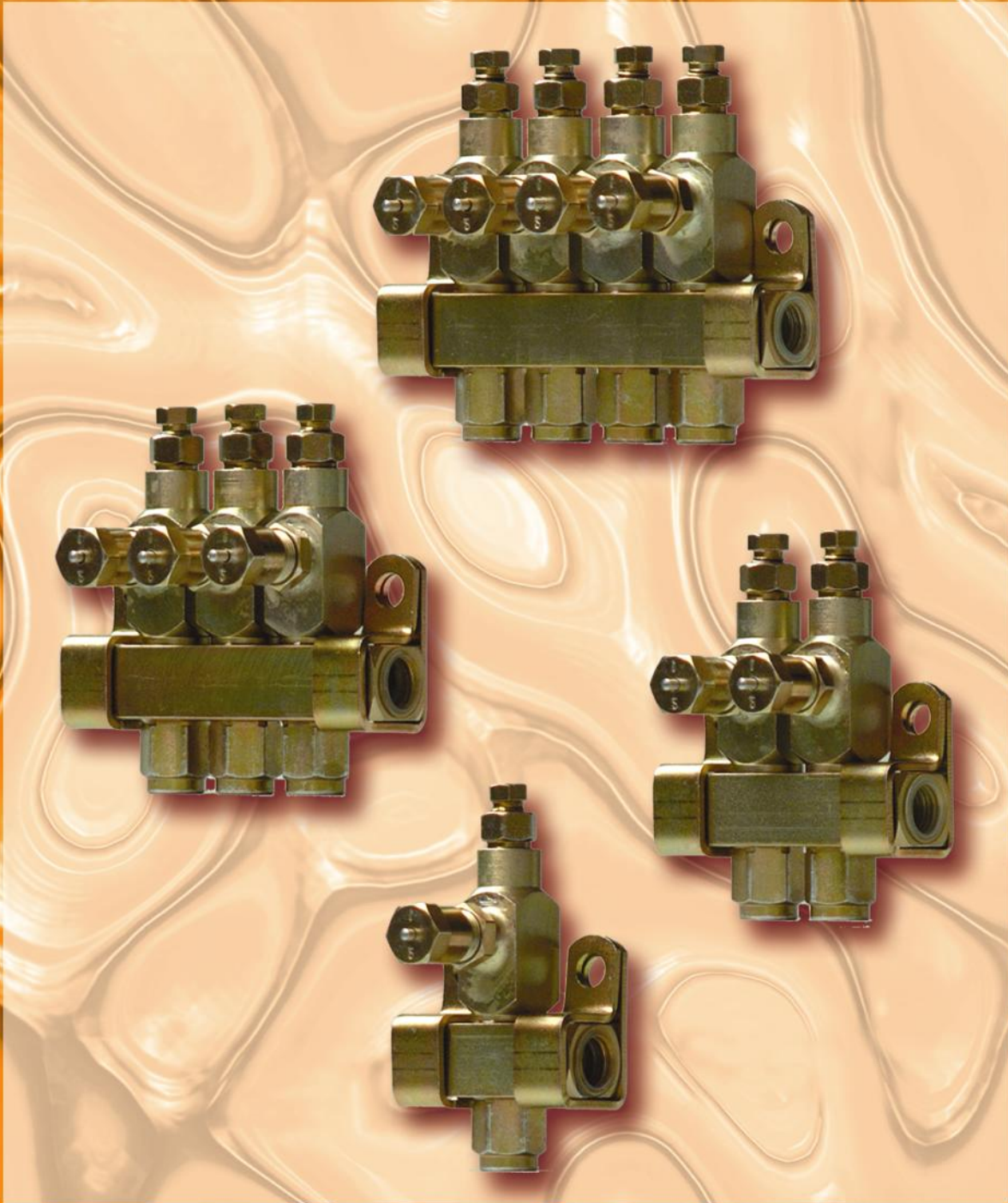

Injector DL - 32

GB
USA

DL – 32 Injector

DL-32 injector has been designed to deliver lubricant to friction points through the feeding line pressure. Flowrate can be adjusted external the unit in order to obtain the flow needed.

These injectors are supplied with visual built-in level indicators to monitoring operation. DL-32 injectors are available in different models: from one to four outlets. Every injector, mounted on a manifold, can be easily replaced or inspected without disassembling the unit or acting on fittings and piping.

These units can be installed in any position and can be used with other types of injectors, if necessary.

Lubricant		Flowrate		Working Pressure			
Oil	Grease	Min	Max	Min	Max	typical	recharge
Min 220 cSt (1018 SUS)	Max NLGI 2	0.02 cm ³ (0.0012 cu.in.)	0.13 cm ³ (0.008 cu.in.)	83 bar (1220 psi)	240 bar (3528 psi)	103 bar (1514 psi)	13 bar (205 psi)

Maximum output is achieved with five turns at 0,026 cm³ (0,016 cu.in) per turn

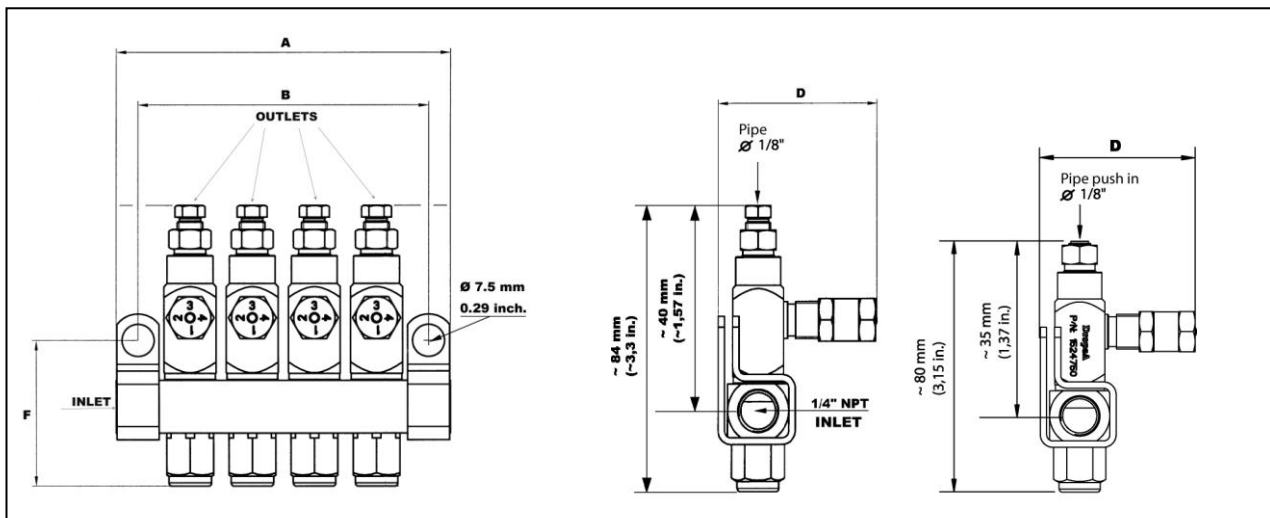

INJECTOR FOR GREASE							
Part n° (steel version)	Part n° (steel version) Push in 1/8"	Part n° (stainless steel AISI 304 version)	N° of outlets	Dimensions mm (inch)			
				A	B	D	F
1524521	1524751	1524921	1	44.5 (1.75)	31.7 (1.25)	~50 (~1.96)	~44 (~1.73)
1524522	1524752	1524922	2	63.5 (2.5)	50.7 (2)		
1524523	1524753	1524923	3	82.5 (3.24)	69.7 (2.74)		
1524524	1524754	1524924	4	101.5 (4)	88.7 (3.5)		

Spare injector	
Version	Part n°.
Steel, pipe 1/8"	1524520
Steel, pipe push in 1/8"	1524750
Stainless steel, taper 1/8"	1524920

Note:

1. Injectors include compression nut and the ring for tubing Ø. 1/8". Other outlet connectors for feed line are optional.
2. Injectors have NBR gasket (194°F/90°C max). Please, check compatibility with synthetic lubricants..
3. Injectors with manifolds include two mounting clips and screws, Ø 1/4" 20 UNC
4. Output with indicator cap hand tightened is 0,02 cm³ (0,0012 cu in).

ITALIA

Dropsa SpA
t. +39 02-250791
f. +39 02-25079767

U.K.

Dropsa (UK) Ltd
t. +44 (0)1784-431177
f. +44 (0)1784-438598

GERMANY

Dropsa GmbH
t. +49 (0)211-394-011
f. +49 (0)211-394-013

FRANCE

Dropsa Ame
t. +33 (0)1-3993-0033
f. +33 (0)1-3986-2636

CHINA

Dropsa Lubrication Systems
(Shanghai) Co., Ltd
t. +86 (021) 67740275
f. +86 (021) 67740205

U.S.A.

Dropsa USA Incorporated
t. +1 586-566-1540
f. +1 586-566-1541

AUSTRALIA

Dropsa Australia Pty
t. +61 (02)-9938-6644
f. +61 (0)2-9938-6611

BRAZIL

Dropsa Do Brasil Ind.e
Com.Ltda
t. +55 (0)11-563-10007
f. +55 (0)11-563-19408

Web site:
<http://www.dropsa.com>

E-mail:
sales@dropsa.com

WK 13/06
C2070PE